

SOLVENT PURIFICATION USING THE GRUBBS APPARATUS GUIDELINE FOR USE

Introduction:

Traditionally, chemists and other laboratory workers who require extremely high purity solvents were forced to purify these solvents by reflux at elevated temperatures, over water-reactive drying agents (Li, Na, K, CaH₂, LiAlH₄). Over the years, there have been many fires and explosions involving thermal distillation apparatus, most recently at the University of California, Irvine. Chemists characterize thermal distillation as one of the most dangerous routine procedures they perform.

In 1996, Pangborn, et al ¹ published in the journal, *Organometallics*, an alternative to thermal distillation. In 2001, Alaimo, et al ² published in the *Journal of Chemical Education*, suggested modifications to the apparatus described by Pangborn. The so-called "Grubbs apparatus" uses a large solvent reservoir and alumina/catalyst columns to dry and de-oxygenate solvents to the desired level of purity; without using heat or water-reactive drying agents. Stakeholders (Fire Departments, researchers, health and safety professionals, to name but a few) are very interested in reducing the risk of fire, explosion, injury, and property damage inherent in thermal distillation. A major goal in the development of this Guideline is to significantly reduce or eliminate the routine use of thermal methods.

In consultation with industry experts, the UC Fire Marshal's Group, UC faculty and staff, and the system-wide Industrial Hygiene & Safety Committee has developed the following Guideline. The intent of this Guideline is to encourage the replacement of thermal methods with safer methods while ensuring compliance with applicable Fire Code, Mechanical Code, Electrical Code, Building Code, Cal/OSHA regulations, and good laboratory safety practices. This Guideline is intended to provide the basis for the design, planning, installation, and operation of Grubbs apparatus for solvent purification in University of California facilities.

Apparatus:

For the purposes of this Guideline, the column solvent purification apparatus will be referred to as the Grubbs apparatus. Others might use the terms "push still," "column purification," or "Grubbs still." The Grubbs apparatus consists of a stainless steel solvent reservoir, (typically 18 liters), one alumina column, one catalyst on alumina column, and a purified solvent delivery port. The reservoir is pressurized (to less than 10 psi) with an inert gas (typically nitrogen or argon), and the solvent is pushed out of the reservoir, through the columns to an evacuated glass flask or delivered directly to the experiment. Columns and reservoirs can be set up in parallel, with carefully labelled valves, to purify several solvents on demand. A small vacuum pump maintains negative pressure on the manifold and collection flasks, and exhausts inert gas at the end of the apparatus. See Figure 1

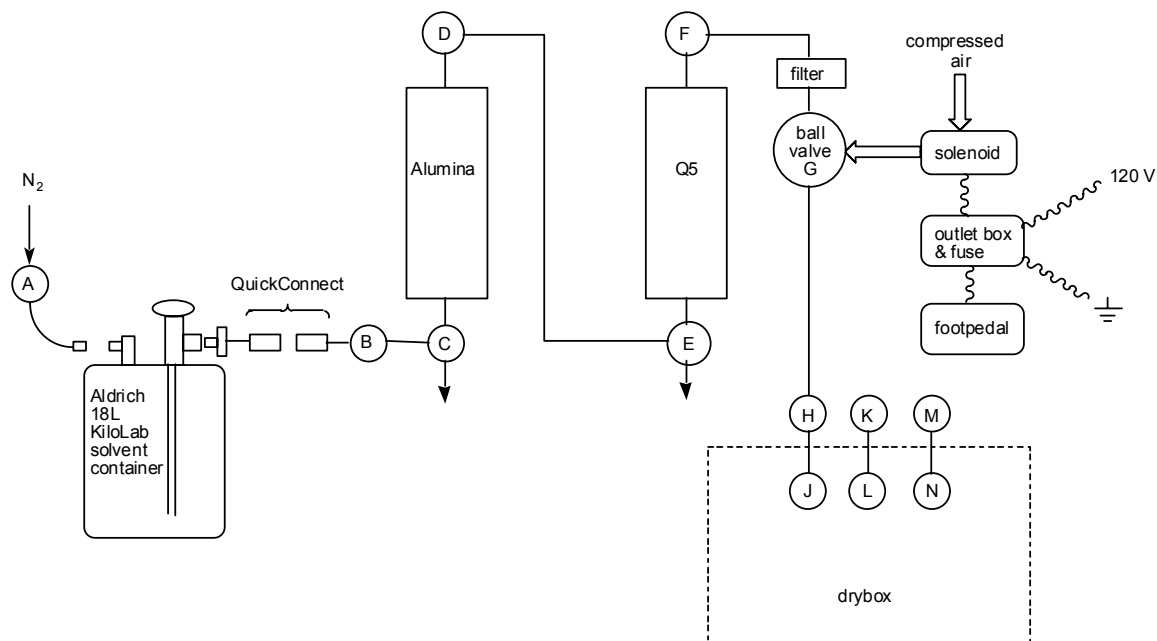

Figure 1 - Schematic of a Grubbs apparatus, used to deliver solvent to a glove box with an inert atmosphere. Alternatively, purified solvent can be delivered to vacuum flasks, etc.

All plans, specifications, standard operating procedures, and operational protocols must be approved by the campus Fire Marshal, in consultation with EH&S.

Guideline:

System Construction:

1. The reservoir container size must be no greater than 19 liters . Most chemical manufacturers provide 18 or 19 liter containers of high purity solvents, already stored under inert gas. These containers have been pressure-tested and many have the appropriate fittings for connection to the Grubbs apparatus. Homemade reservoir containers, such as those made from empty propane bottles, are not permitted.
2001 CFC, Table 7902.1-A
2. When fully assembled on site, a final pressure check of the apparatus shall be performed. .
Pressure check requirements are described in Section 1406.2.2 of the California Mechanical Code (2001)
3. All solvent reservoir containers shall be stored in flammable liquid storage cabinets.
Section 7902.5.9 of the CFC (2001).
4. All solvent transfer tubing and fittings shall be stainless steel.
Refer to the requirements of Section 7901.11 of the CFC (2001) for additional details.

5. All valves and tubing shall be clearly labeled in accordance with the requirements of ANSI A13.1, 1996 edition.
 - a. A system piping and instrumentation diagram (P&ID) must be submitted to the Fire Marshal for review.
 - b. Arrows shall be used to indicate the direction of the flow.
 - c. Piping should be color-coded. Labeling of the contents of the piping should be applied as close to the color bands as possible.
 - d. Color identification must be consistent throughout the system.
6. Install low volume quick disconnects on the top of the solvent reservoir and on the purification columns to minimize spillage during change out procedures.
7. All apparatus and ancillary equipment must be seismically braced.
Section 1634A of the CBC (1998).
8. The vacuum pump is an integral component of some versions of the Grubbs apparatus, to maintain negative pressure on the system and exhaust gas and vapors. The vacuum pump exhaust must be metallic and ducted to the fume hood exhaust or general laboratory exhaust. Pump exhaust shall not be returned to the building. Some versions of the Grubbs apparatus, because of where the purified solvent is delivered, do not require a vacuum pump. An apparatus set up to deliver solvent directly into a glove box does not require a vacuum pump.
9. The Grubbs apparatus must be installed on a dished work surface, similar to the work surface of a chemical fume hood, capable of containing a small, incidental spill. Secondary containment is integral to flammable liquid storage cabinets, which are required for storage of the solvent reservoir(s). Any plumbing from the solvent reservoir, through the work surface into the apparatus must be sealed with fire resistant caulk (i.e., FireStop) or sealed with the appropriate bulkhead fitting.
10. The room, laboratory or area where the Grubbs apparatus are placed shall have a clear and unobstructed exit. Aisle width may not be less than 36 inches.
CBC (2001), section 1007.4, section 304.2.2.11 and section 307.4
Check CBC section 1004.3.2 - aisle width may be required to be greater, depending on occupancy, location of exit doors, and how the space is arranged.
11. Specifications, from the apparatus' designer and/or manufacturer, plans for installation conforming to the manufacturer's instructions and this Guideline must be submitted to the Campus Fire Marshal for review and approval.

Local Exhaust Ventilation

12. For new facilities, the Grubbs apparatus must be installed in a fume hood or other, 3-sided exhausted enclosure (i.e., backdraft exhaust system) with a minimum of 25 cfm per square foot of internal work surface. For existing facilities, if it is not possible to install the apparatus in an exhausted enclosure, the general exhaust in the laboratory must be at least 10 air changes per hour, with the Grubbs apparatus installed so that good dilution ventilation is possible. If not installed in a fume hood or 3-sided enclosure, the apparatus must be installed and used in a well-ventilated laboratory and not in a converted closet or storage room.

NFPA 45, A.6.4.6

Electrical Safety

13. Based on the California Electrical Code, 2001, section 500-7 (b), the Grubbs apparatus meets the definition of a Class 1, Division 2 location. The vacuum pump installed on the apparatus must meet the requirements of section 501-8 (b) and be located apart from the apparatus - outside of the exhausted enclosure or away from the flammable liquid storage cabinets is optimum. An explosion-proof vacuum pump, designed to be used in areas where there are flammable vapors, may be used next to the Grubbs apparatus.

Details describing distances are in Section 500 of the CEC (2001) and Article 79, CFC (2001).

14. An emergency shut-off switch or valve must be provided, to prevent any uncontrolled release from the solvent reservoir, should the apparatus develop a leak. Consideration should be given to an emergency vent valve (in addition to the emergency shut-off valve), to release pressure on the apparatus, should the apparatus develop a leak.
15. The Grubbs apparatus and solvent reservoirs must be properly grounded and bonded. If quick connect fittings are used, make sure the fittings are electrically bonded.

Alarms, Fire Detection and Suppression

16. The Grubbs apparatus must be installed in a location with an automatic smoke detection system that is interconnected with the building fire alarm system.
17. For new facilities, automatic fire suppression must be applied. For existing facilities, consideration should be given to local fire suppression at the apparatus installation. An ABC fire extinguisher (with a minimum rating of 3A:40BC) must be available within 10 feet of the apparatus.

System Operation

18. If the system is not installed in a ventilated enclosure, personal protective equipment and corresponding care must be used appropriate to the hazards of the solvents when disconnecting the columns for reactivation or replacements. The current exposure limits for many common solvents (benzene, dichloromethane, etc.) are quite low and may require respiratory protection during non-routine operations.

19. If the solvent reservoir needs to be re-filled, the solvent transfer must be done in a fume hood. A pump with proper, anti-static tubing, must be used for transferring solvents from large (>5 gallons) containers.
20. The Principal Investigator, in consultation with the Grubbs apparatus designer and/or manufacturer, must prepare a laboratory and equipment specific Standard Operating Procedure addressing reservoir filling, solvent degassing, apparatus operation, dispensing, etc., for the safe operation of the apparatus. The SOP's and design document (P&ID) will be used as training tools to facilitate the Principal Investigator's training of end users.
21. A written SOP must also be developed for activation of the column beds. If the resin beds will be reused, a regeneration procedure must be developed.
22. All users of the Grubbs apparatus must participate in safety and operation training and read and follow all written SOP's. All training must be documented and maintained by the department.
23. All Grubbs apparatus must adhere to manufacturer's installation instructions and Campus Fire Marshal/Environmental Health and Safety direction.

Vendors

24. Glass Contour: <http://www.glasscontour.com>
Innovative Technology: <http://www.solventpurification.com>

References

- ¹ Pangborn, A.B., Giardello, M.A., Grubbs, R.H., et al; *Organometallics*, **15**(5), 1518-1520, 1996.
- ² Alaimo, Peter J.; Peters, David W.; Arnold, John; Bergman, Robert G.; *J. of Chem. Ed.* **2001** 78 64.

Acknowledgements

The UC Fire Marshals Group and UC Industrial Hygiene and Safety Committee gratefully acknowledge the Office of Environmental Health and Safety at UC Irvine and the following individuals for their valuable input into this Guideline:

Jorg Meyer, UCI
Rebecca Lally, UCI
Dale Saunders, UCI
Rama Singh, UCI